

Numerical control for Shear

CybTouch 8

CybTouch 8 for Shear is available on two versions: CybTouch 8 G, designed for adjustable rake angle shears, and CybTouch 8 W, dedicated more to control swing shears.

As part of the CybTouch numerical controls' family, CybTouch 8 for Shears was designed with the OEM's needs in mind. Offering a broad range of machine functionalities in a very accessible way, it can thus be easily and precisely fine-tuned to accurately match the needs of the machine it controls.

Boasting a very user-friendly touch screen interface, CybTouch 8 for Shears is a sober and practical numerical control that will make any end user feel immediately at ease.

High speed RLink wireless communication facilitates backup, restore, data transfer functions with laptop computers.

CybTouch 8 for Shears is delivered as a robust panel, or can optionally also be available integrated into a sleek and modern housing.



Standard software specifications

User friendliness

Excellent readability thanks to the large characters, big buttons and vivid colors. So intuitive that the user can be operational in no time. Visit the [Video section of our web-site](#) and see for yourself. Pop-up messages for security or external malfunctions.

EasyCut page

Is displayed as start up page for easy use. Provides immediate easy use of the machine for any new user.

Screen content

Can be simplified to its bare necessities by removing all unused functions, buttons or information.

Wizards

Complete set of Wizards to help setting up axes, gains, speeds, blade gap(s) and indexes. Machine startup is made very simple and straightforward. Time of setup is significantly reduced and more reliable.

Configuration

Axes configuration, inputs/outputs and auxiliary functions can be made to precisely fit the specific needs of the machine. Internal timers can be setup for smooth valve commutation.

Memory capacity

- Up to 10 types of materials
- 200 Programs
- 24 Sequences per program

Hardware specifications

Housing or panel version

Delivered as a robust panel ready to be integrated, or optionally directly integrated into a sleek and modern housing specially designed to be attached to a swiveling arm.

Integration

Reduced electrical wiring, electrical cabinet size and equipment for lower set-up costs on each shear. Can easily be integrated into the electrical box diagrams. Possibility to manage the angle and cutting length using potentiometers (only on 8 G), linear encoders (only on 8 G) or a timer.

Electrical connections

Earthing and wiring of the cables designed to make the process as straightforward as possible.

New indexing functions

Wizard functions make the definition of indexes a lot simpler, quicker and more precise.

Wireless communication

RFLink wireless radio frequency data communication (need optional RFLink USB key) allows backup, restoring and firmware upgrades operations without any cable connection to the numerical control.

Energy

Energy saving thanks to the integrated Eco mode function that automatically stops the main pump after a chosen time of inactivity.

Original parameters

Internal backup in a special safe memory allows the user to restore at any time the original parameters; machine is running again in an extremely short time in the event of a memory loss or involuntary parameter modification.

Encoders

CybTouch 8 for Shears accepts encoders with or without complementary signals.

Axis and cutting functions

The following elements are available and can be configured on the CybTouch 8 for Shears by the OEM. However, some functions depend on the machine construction.

i Features availability depends on the number of available axes and inputs/outputs.

BACK / FRONT GAUGE AXIS	CBT-8G	CBT-8W
Wizards and auto-tuning of the axes.	✓	✓
High precision and fast positioning algorithm for frequency converter axes.	✓	✓
Retraction of the back gauge during the cutting process can be configured.	✓	✓
Back gauge management or front gauge management.	✓	✓
Indexing in several modes.	✓	✓
Inch / mm.	✓	✓

SHEAR FEATURES	CBT-8G	CBT-8W
Eco mode.	✓	✓
Linearization of the blade gap curve for optimal positioning accuracy.	✓	✓
Blade gap with 1 actuator.	✓	✓
Blade gap with 2 actuators.	✓	✗
Backgauge clearance during the cutting process (yes / no).	✓	✓
Management of sheet support with 2 or 3 positions integrated in machine cycle.	✓	✓
RTS (Return to sender) function.	✓	✓
Mechanical foldaway.	✓	✓
Hydraulic foldaway.	✓	✗
Cutting length management by potentiometer.	✓	✓
Cutting length management by encoder.	✓	✗
Cutting length management by timer.	✓	✓
Sequence repetition.	✓	✓
AutoCut (Flying Cut or continuous cut) function.	✓	✓

SHEAR FEATURES	CBT-8G	CBT-8W
Anti-twist management.	✓	✗
Screen button for cutting laser / light guide.	✓	✓
Counting of the parts up or down, with auto-stop.	✓	✓
Time and stroke counters for oil service.	✓	✓
Sheet offset (multiple-cuts in the middle of the machine with reduced TDC).	✓	✗
Automatic management of blade gap.	✓	✓
Automatic management of cutting angle and cutting length.	✓	✓ (timer)
System pressure management with ramp for pressure proportional valve.	✓	✗
Pump start button.	✓	✓

Technical Characteristics

	CYBTOUCH 8 G	CYBTOUCH 8 W
Screen	7" color graphic CRT screen, with LED backlight control.	
Resolution	800 x 480 pixels (WVGA)	
Work memory	SRAM	
System memory	FLASH memory with firmware update via RFLink.	
Communication	Cybelec RFLink (radio frequency link).	
Axis	<ul style="list-style-type: none"> • ± 10VDC management of AC/DC drives and motors. • 0-10 VDC frequency converter for AC asynchronous motors. • SP-SN-HS 2 speeds mode. • SP-SN 0-10 VDC 2 adjustable speeds. 	
Units	inch/mm conversion.	
Power supplies	<ul style="list-style-type: none"> • Numerical control: stabilized + 24VDC -15% / + 20% 6W • Digital inputs/outputs: stabilized + 24VDC -15% / + 20% 	
Encoder inputs	2 5 VDC or 12 VDC* or 24 VDC* (* = external power supply). Complementary signals are not necessary, but recommended.	1 5 VDC or 12 VDC* or 24 VDC* (* = external power supply). Complementary signals are not necessary, but recommended.
Power supplies for encoders	5 VDC Supplied by CybTouch. Max. 250 mA for each encoder.	
Digital inputs	8 Optocoupled.	
Analog inputs	2 0-10 VDC.	1 0-10 VDC.
Digital outputs	12 Optocoupled and fuse protected. 24 VDC source mode, max. 0.7 A. Possibility to configure twice the same output to double the current.	
Analog outputs	3 ±10 VDC Impedance < 100 Ω, short circuit proof. Load ≥ 2 kΩ (max 15 mA).	1 ±10 VDC Impedance < 100 Ω, short circuit proof. Load ≥ 2 kΩ (max 15 mA).
Reference voltage	1 10 VDC (max 20 mA) for external potentiometer (recommended value 2kΩ to 5kΩ).	
Operating conditions	Min. 5° Celsius, max. 45° Celsius. Relative humidity 10 to 85% non-condensing.	
EC Directives	IEC61131-2.	
Available languages	English, Français, Deutsch, Italiano, Nederlands, Español, Português, Português Brasil, Český, Türkçe, 中文, 台灣, Polski, Русский	

Dimensions

Box version

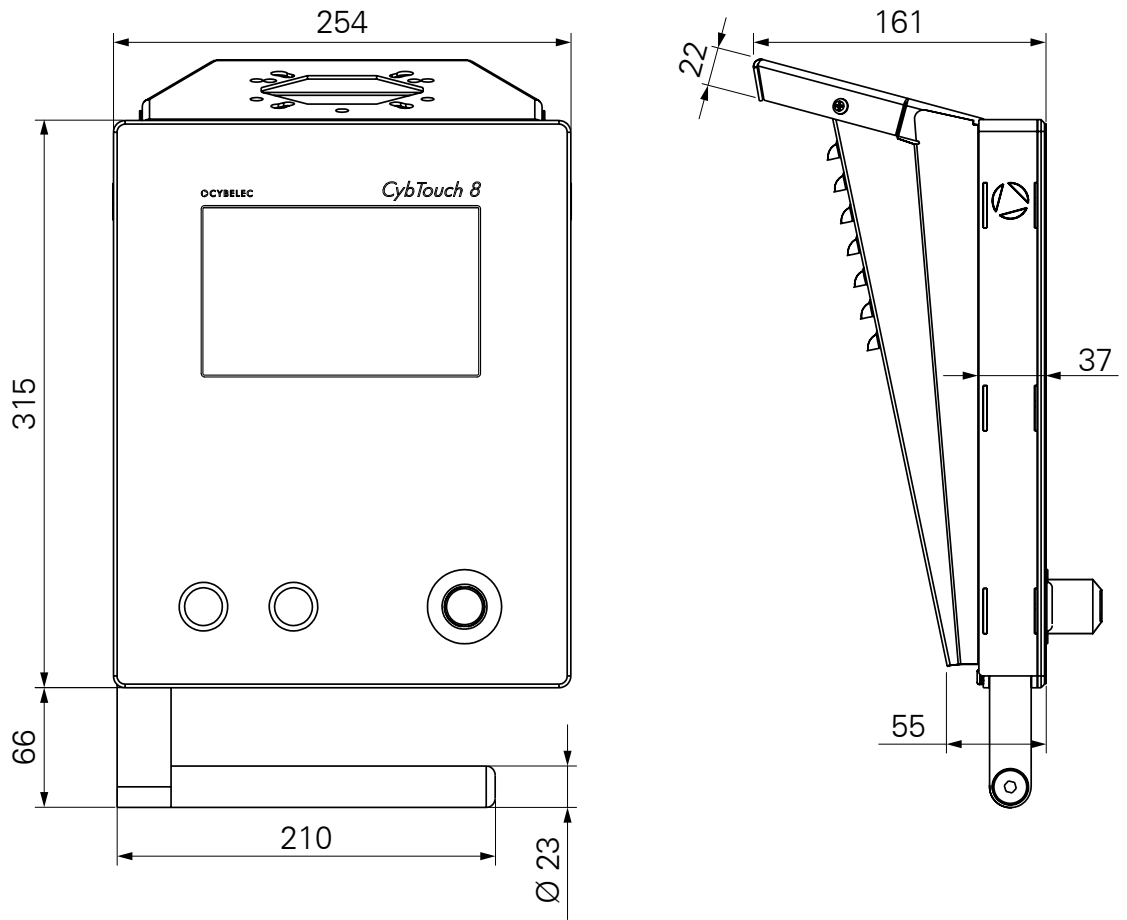

Attachment dimensions

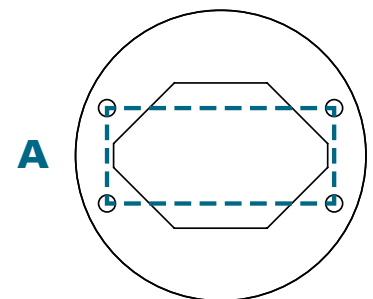
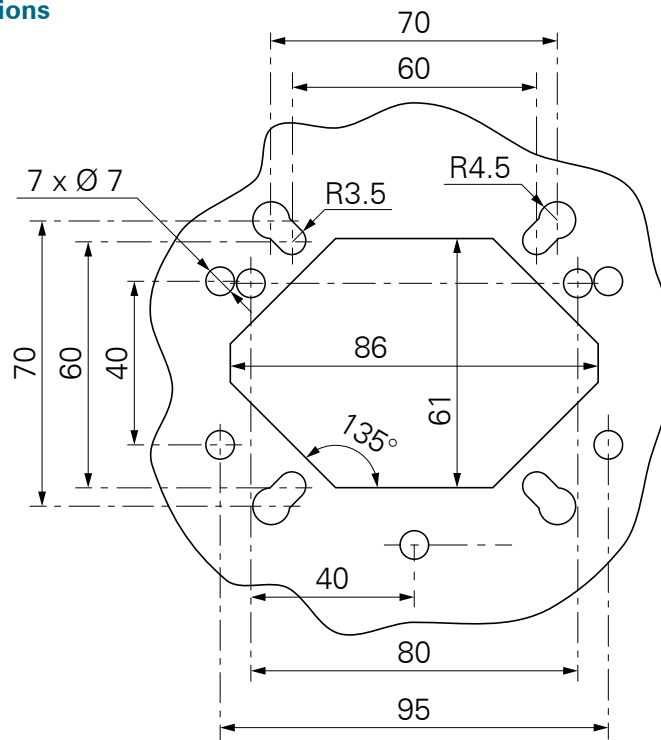

A 40 x 95

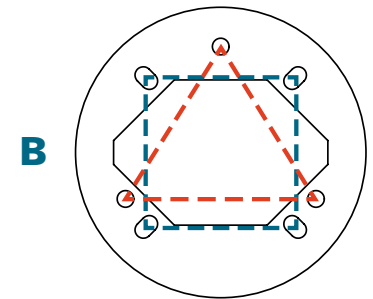

B 60 x 60 or 65 x 65

△ 80 x 80 x 80

Two adapters are provided. Stick the appropriate one on top of the box, to blind open holes if necessary.

Panel version

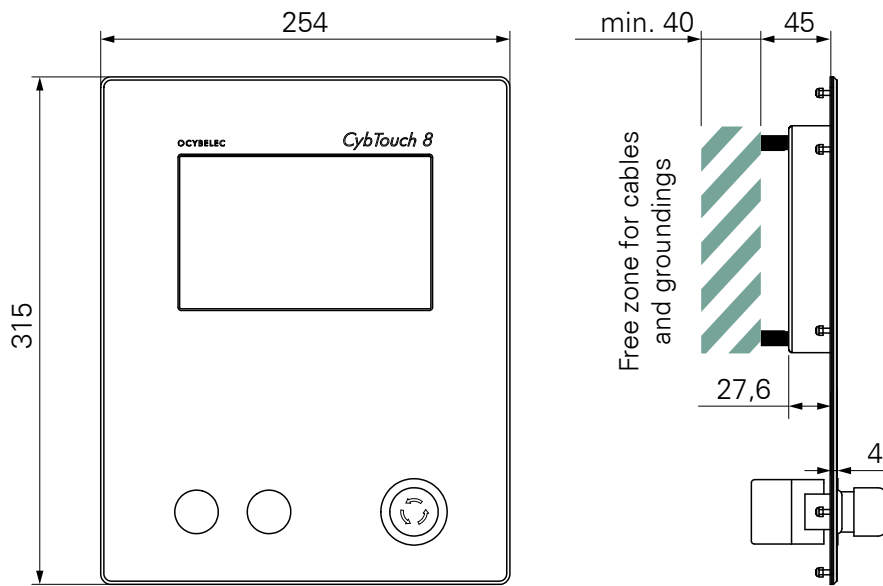

Small panel version

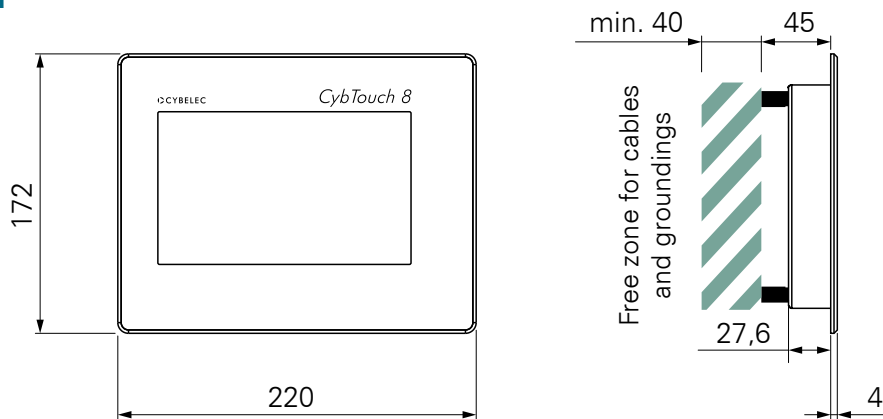

Integrating opening dimensions

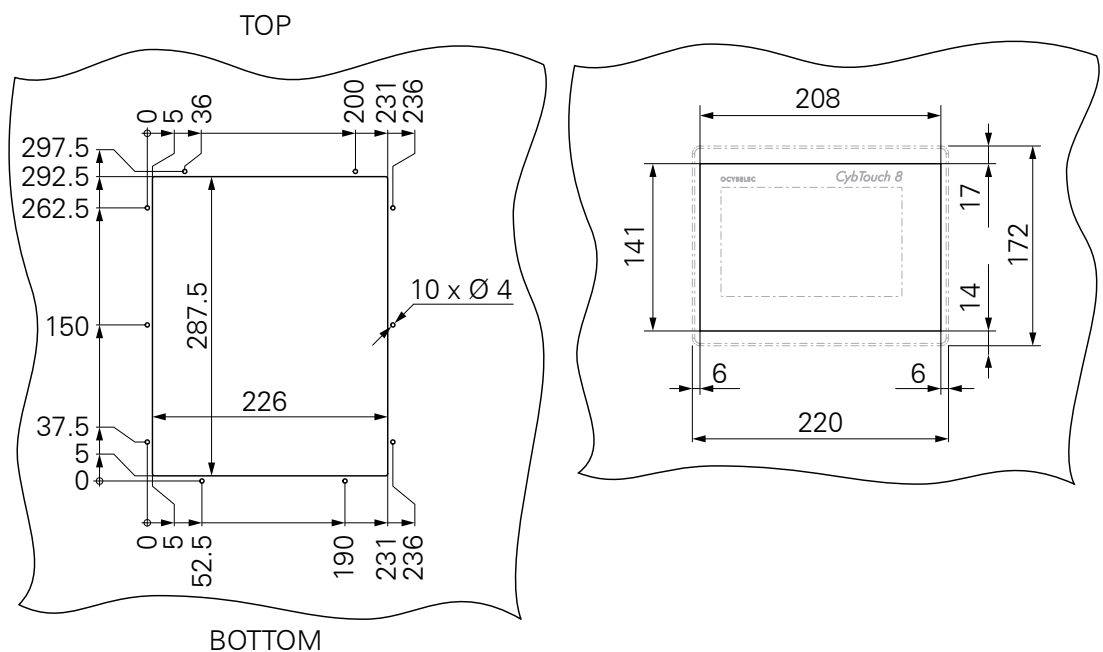

Possible potentiometer and encoder combinations

CONFIG.	CUT. LENGTH & ANGLE	GAP 1	GAP 2	BACK / FRONT GAUGE	
CybTouch 8 G	1	Encoder	Potentiometer	n/a	Encoder
	2	Timer	Potentiometer	n/a	Encoder
	3	Potentiometer	Potentiometer	n/a	Encoder
	4	Encoder	Potentiometer	Potentiometer	Encoder
	5	Timer	Potentiometer	Potentiometer	Encoder
CybTouch 8 W	1	n/a	Potentiometer	n/a	Encoder
	2	Timer	Potentiometer	n/a	Encoder

Options & Accessories

S-OPT-RFLINK	RFlink USB key for PC including CybTouchTools software
S-MVP-100/A	Pressure valve amplifier

Ordering Information

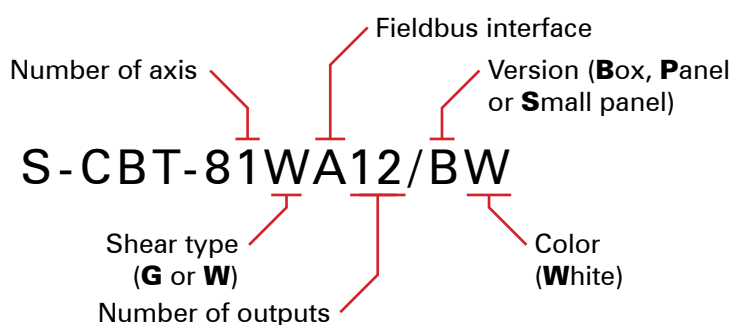

Available models

S-CBT-81GA12/BW
 S-CBT-81GA12/P
 S-CBT-81GA12/S
 S-CBT-81WA12/BW
 S-CBT-81WA12/P
 S-CBT-81WA12/S